

High density polyethylene drained cavity former for waterproofing of sub-structures

Uses

Proofex Cavitydrain is used where sub-structures are constructed in concrete designed to minimise water entry in accordance with BS 8102:2009 'Protection of structures against water from the ground', Type C.

Any water ingress through the structural concrete will not enter the internal environment because Proofex Cavitydrain provides a continuous water and damp proof drainage former to connect with drainage channels or outlets cast into floor slabs.

Water leakage problems which show up in the construction stage can be remedied before the drainage layer is put in place, adding to the security of the waterproofing system

Advantages

- Internal application in a controlled environment increases security against waterproofing failure
- Provides a continuous drainage former and damp proof barrier
- High compressive strength
- Conical voids enable high load transfer to structural elements
- Chemically resistant
- Easily fixed and installed using mechanical fixings
- Vertical and horizontal grades available

Description

Proofex Cavitydrain products are profiled HDPE with ribbed conical voids spaced to permit high water flow through a permanent void against the sub-structure face.

Mortar is poured into the conical voids on the internal face of the drainage former allowing high load transfer to structural elements.

Two grades are available. Proofex Cavitydrain 80 is a cost effective solution for vertical applications and Proofex

Cavity drain 200 is for both horizontal and vertical applications

Properties

	Proofex Cavity drain	
	80	200
Void height:	8 mm	20 mm
Vertical drainage capacity under 0kPa EN ISO12958:	1.65 l/s/m	10 l/s/m

Horizontal drainage capacity under 20kPa EN ISO12958:	0.30 l/s/m	2.5 l/s/m
Compressive strengths ISO 25619-2:	200 kN/m ²	150 kN/m ²
Chemical resistance:	Resistant to most acids,alkalis, oils and fuels	

Application Instructions

Ensure drainage system is free from obstructions. Check floor slab is laid to adequate falls and all channel and outlet grills are fixed. Make good any defects to concrete surfaces that would prevent adequate fixing of Proofex Cavitydrain.

Cut Proofex Cavitydrain to length allowing for the connection detail at the drained wall cavity. Ensure the bases of the conical voids always face the substrate.

Fix along the opening jointed edge by mechanical fixing with Steel Hammer-in Anchors (6mm diameter x 30mm overall length) at 1000 mm centres. If shot fired fixing is preferred use Hilti XSW 30 fasteners or similar. In both cases apply a small quantity of Fosroc Plastiseal into the conical void before mechanical fixing to ensure continuity of the damp proof barrier.

Edge laps between adjacent sheets of Proofex Cavitydrain should be formed by bonding with self-adhesive foam strip or a bead of Plastiseal. The minimum overlap should be 25 mm and fixed firmly together using 10 mm long self tapping screws at 300 mm centres. Use fixings at 1000 mm centres in the conical voids adjacent to the formed edge lap.

Where projections through the floor slab occur trim Proofex Cavitydrain to butt against the projection. Fill three rows of conical voids around the perimeter of the projection with mortar or concrete and allow to dry. Prime the face of the projection and the area of filled conical voids with Proofex Primer and allow to dry.

Flash around pipes and column bases using Proofex 3000 membrane to provide continuity of water proofing (see detail).

Proofex Cavity drain

Example of Proofex Cavitydrain at floor slab / column base joint



- 1 Fosroc Proofex Cavitydrain
- 2 Fosroc Proofex Angle Fillet membrane
- 3 Insulation if required
- 4 Floor screed
- 5 Fosroc Proofex 3000

Where a joint occurs between horizontally and vertically applied Proofex Cavitydrain, it may be formed by first fixing the wall cavity former terminated 20 to 30 mm above floor slab level.

The floor cavity former is then bent through 90 degrees up the wall, interlocking the first two rows of conical voids into the wall cavity former (see detail).

Example of Proofex Cavitydrain at joint between wall and floor/

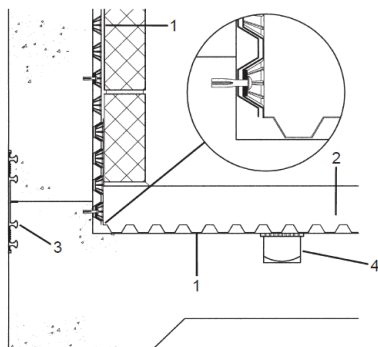

- 1/ Fosroc Proofex Cavitydrain
- 2 Floor screed
- 3 Fosroc Supercast Rearguard S Waterstop
- 4 Channel connected to site drainage system

Where this detail is not possible butt the horizontal sheet against the vertical sheet ensuring both drainage planes drain freely into the drainage channel (see alternative detail).

Example of Proofex Cavitydrain at joint between wall and floor (alternative detail)

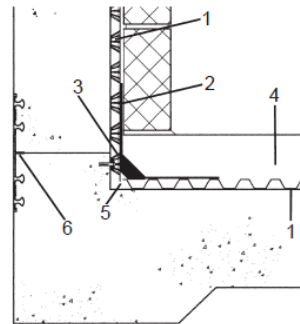

- 1 Fosroc Proofex Cavitydrain
- 2 Fosroc Proofex 3000 membrane flashing
- 3 Fosroc Proofex Angle Fillet
- 4 Floor screed
- 5 Butt joint
- 6 Fosroc Supercast Rearguard S Waterstop

Fill the first three rows of conical voids in the horizontal Proofex Cavitydrain with mortar or concrete and allow to dry. Prime surface with Proofex Primer. Apply Proofex Angle Fillet and a 300 mm strip of Proofex 3000 membrane as a closure strip between the horizontal and vertical Proofex Cavitydrain.

Estimating

Proofex Cavitydrain 80

Roll size: 2 m x 30 m
Roll weight: 30 kg

Proofex Cavitydrain 200

Roll size: 2 m x 20 m
Roll weight: 40 kg

Proofex Cavity drain

Limitations

If it is not possible to cast floor screeds immediately following the application of Proofex Cavitydrain, temporary protection must be provided to prevent physical damage from site operations.

Avoid point loads of Proofex Cavitydrain from floor screed reinforcement by using spreaders or pre-filling the conical voids with concrete or mortar.

Storage

Store in original unopened packaging, in cool dry conditions, away from sunlight.

Precautions

Health and safety

Each Proofex Cavitydrain roll should be lifted by a minimum of two site operatives.

For Proofex Primer refer to Product Safety Data Sheet.

Proofex Cavity drain

Important note :

Fosroc products are guaranteed against defective materials and manufacture and are sold subject to its standard terms and conditions of sale, copies of which may be obtained on request. Whilst Fosroc endeavours to ensure that any advice, recommendation specification or information it may give is accurate and correct, it cannot, because it has no direct or continuous control over where or how its products are applied, accept any liability either directly or indirectly arising from the use of its products whether or not in accordance with any advice, specification, recommendation or information given by it.



Berger Fosroc Limited

Corporate Address:

'Berger House', House # 08, Road # 02, Sector # 03, Uttara Model Town, Dhaka 1230, Bangladesh.

telephone(Hunting) : +880248953665, **fax** : +880248951350,

e-mail : enquiry.bangladesh@bergerfosroc.com, **website** : www.bergerfosroc.com

